

Floss Machine

Instruction Manual Model #3024EX





 **GOLD MEDAL**[®]
FUNFOOD EQUIPMENT & SUPPLIES

Cincinnati, OH 45241-4807 USA

Safety Precautions

| | |
|---|--|
|  | ⚠ CAUTION |
| | <p>This equipment is designed and sold for commercial use only. This equipment is not to be used by the consumer in home use. Do not allow direct contact of this equipment by the public when used in food service locations. Only personnel trained and experienced in the equipment operation may operate this equipment.</p> <p>Carefully read all installation instructions before operating the equipment.</p> |

| | |
|---|--|
|  | ⚠ WARNING |
| | <p>Floss head rotates at 3450 RPM. Operator must keep hands and face clear of the floss head and keep spectators at a reasonable distance.</p> |

| | |
|--|---|
|  | ⚠ WARNING |
| | <p>Any alterations to this equipment will void the warranty and may cause a dangerous situation. NEVER make alterations to the equipment.</p> |

| | |
|---|--|
|  | ⚠ DANGER |
| | <p>Machine must be properly grounded to prevent electrical shock to personnel. Do NOT immerse the equipment in water.</p> <p>Always unplug the equipment before cleaning or servicing.</p> |

NOTE

The information, specifications and illustrations contained in this manual represent the latest data available at time of publication. Right is reserved to make changes as required at the discretion of Gold Medal Products Company without notice.

INTRODUCTION

Your Floss Machine warranty is described on the back page of this manual. This does NOT cover the ribbons, bands or motor bearings since, they can be damaged by the operator.

After unpacking, check thoroughly for any damage which may have occurred in transit. Claims should be filed immediately with the transportation company. The warranty also does not cover damage that occurs in transit or damage caused by abuse or consequential damage due to the operation of this machine, since it is beyond our control.

ELECTRICAL REQUIREMENTS



The GOLD MEDAL Floss machine requires a 240 volt, 50 cycle standard wall receptacle.

The power supply cord is equipped with a machine ground (the tubular prong on the male plug). For safety, always plug the machine into a grounded receptacle, which has been tested for proper polarity to insure electrical safety.

BEFORE PLUGGING IN THE MACHINE

Remove all padding and restraints.

Lower the shipping bracket so the bell housing "floats" freely on the springs. Unscrew and push down the two knobs on each side of the cabinet top to lower the shipping bracket completely.

Make sure the floss ribbon (heating element) located inside the head assembly has not shaken out of the band during transportation. If the ribbon is out of the band, push it back into place manually.

CONTROLS AND FUNCTIONS

MAIN SWITCH - Turns motor "on" or "off" and supplies current to the heat switch.

HEAT SWITCH - Turns current to the heating element (ribbon) "on" or "off."

HEAT CONTROL - Increases or decreases voltage to ribbon wire heating element using a graduated dial.

OPERATING INSTRUCTIONS

The easiest way to make sure you have the right texture sugar with proper flavor and colors is to use GOLD MEDAL FLOSSUGAR. FLOSSUGAR gives good, rich colors and flavors, and does not exceed the color limitations imposed by the Food and Drug Administration. FLOSSUGAR comes in sealed, plastic-coated cartons with handy pouring spouts for filling. If you use your own flavors in cotton candy, make sure they are not gum or starch based; these items burn on the ribbons.

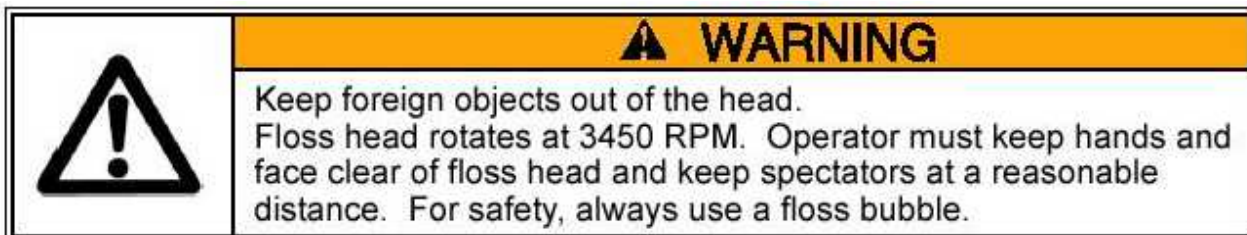

Heat Control Setting Test

1. Follow the guidelines described on page 1 for supplying power to machine.
2. With main switch still OFF, fill floss head. Always fill it 90% full with sugar. This 90% level is necessary to obtain a balanced condition in the floss head. DO NOT OVERFILL! Excessive vibration will occur if overfilled. Before turning the power on, manually turn the head to balance out the sugar. This will eliminate excessive vibration of the head.

Important: NEVER add sugar when motor is running.

3. Turn MAIN SWITCH and HEAT SWITCH "ON."
4. Turn heat control knob clockwise to maximum setting to initiate the fastest possible warm up.
5. The machine should start making floss in a few seconds. When the unit starts making floss, you must reduce the heat setting. Turn the heat control knob counter clockwise to eliminate smoking. If you operate the unit at "start up" setting, you will "carbonize" the ribbon.

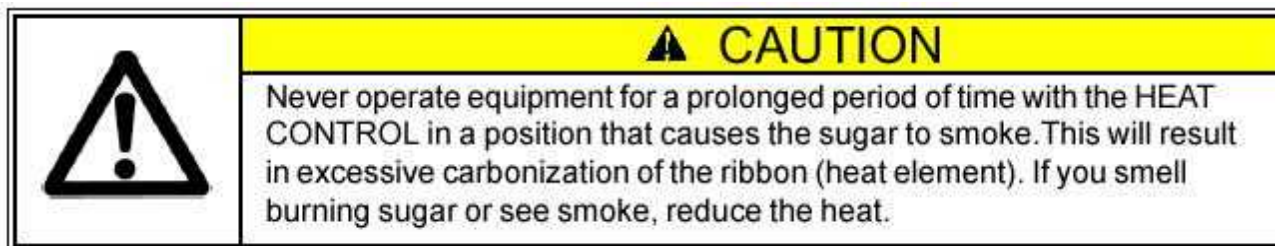

6. Once you find the ideal setting for the HEAT CONTROL, operate with the setting near this position each time.

MAKING FLOSS



Pick a cone; if it sticks in the stack of cones, twist it off the stack.

Hold an inch or two of the pointed end of the cone between two fingers and a thumb. With a light flicking action, roll cone in the web of floss building up in the pan. Lift the cone up with the ring of floss attached and rotate the cone to wrap the floss. **DO NOT** roll floss while the cone is inside the pan. This will pack the floss too tightly.

If the floss fails to stick to the cone, pass the cone near the spinner head to pick up a "starter" of melted sugar. Lift the cone out of the pan and wrap the floss with a "figure eight" movement of the hand. This leaves giant pockets and makes the final product appear larger. Make sure room humidity is not too high, or product will be "heavy".

1. Grip cone as shown.
2. Break into web of floss with the cone.
3. Wind the sugar onto the cone.
4. Lift web of floss from the pan and roll onto the cone.

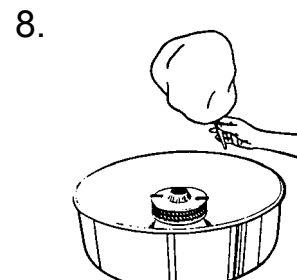
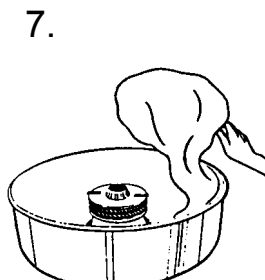
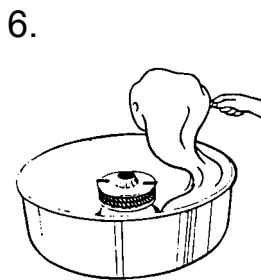
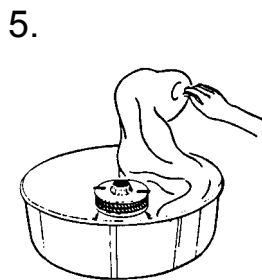
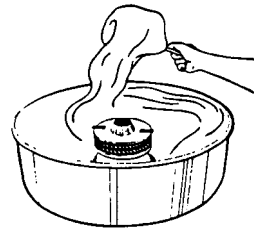
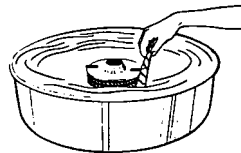
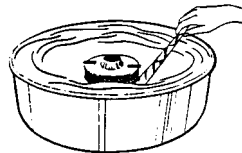
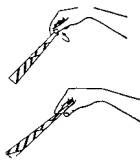

- DO NOT PUT HANDS OR OBJECTS IN ROTATING SPINNER HEAD.
- DO NOT FILL SPINNER HEAD WITH SUGAR WHILE IT IS ROTATING.
- WEAR EYE PROTECTION
- DO NOT PUT HANDS NEAR ROTATING SPINNER HEAD,
- USE FLOSS CONE TO COLLECT COTTON CANDY.

FLOATER ADJUSTMENT

In operation, the floss will collect on the FLOSS STABILIZER (if used). If the floss collects “low” on the stabilizer, twist the front (leading) edge of the leather floaters down. You get more lift and the floss will collect higher.

Form leather floaters as shown. This creates a lifting action to float the floss higher on the outside wall of the floss pan.

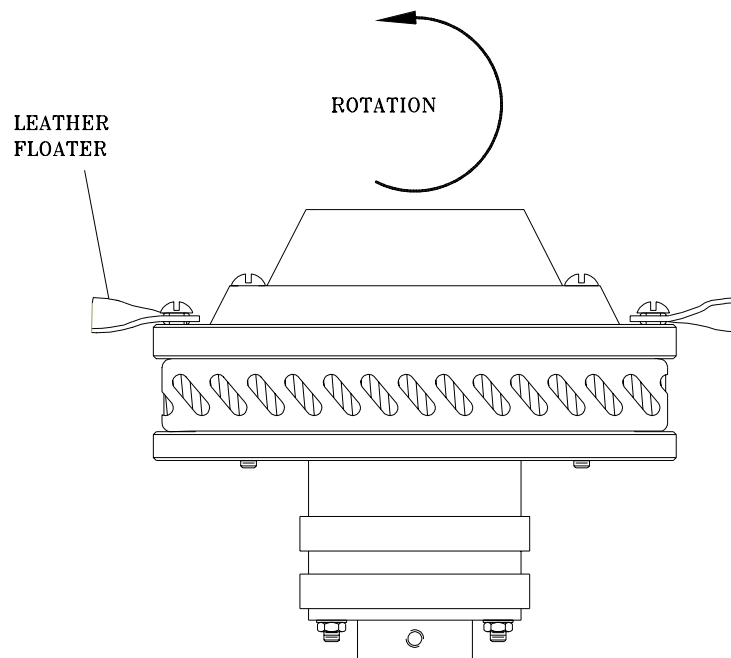



SHUT DOWN PROCEDURE

When completing operation for the day (or any prolonged period), run all the sugar out of the floss head. When empty, turn the heat to highest position for approximately one minute to “clean” the band by baking off remaining sugar. NEVER put water in the floss head.

MAINTENANCE INSTRUCTIONS

| | |
|---|--|
|  | ⚠ CAUTION |
| | THE FOLLOWING SECTIONS OF THIS MANUAL ARE INTENDED ONLY FOR QUALIFIED SERVICE PERSONNEL WHO ARE FAMILIAR WITH ELECTRICAL EQUIPMENT. THESE ARE NOT INTENDED FOR THE OPERATOR. |

| | |
|--|--|
|  | ⚠ WARNING |
| | Adequate eye protection must be used when servicing this equipment to prevent the possibility of injury. |

| | |
|---|---|
|  | ⚡ DANGER |
| | Do NOT immerse the equipment in water. Unplug your machine before servicing. |

FLOSS BANDS AND RIBBONS

The GOLD MEDAL Floss machine is equipped with a patent pending FLOSS BAND designed to give long life, trouble-free service with little care. DO NOT scratch the band. To clean, unplug the machine and wipe with a damp cloth.

GOLD MEDAL Floss Ribbons (heat elements) are made of nickel wire with insulation at the terminal point and on the lead wires. They are designed to be as reliable as the GOLD MEDAL Floss Bands: however, the ribbons must be handled carefully. DO NOT stretch the ribbon or it will not function properly.

Disassembly and Removal

1. Remove all sugar from the head of the machine before disassembling. If the unit is inoperative, carefully turn the machine on its side and shake the sugar out.
2. Remove the four spinner cap retainer screws and spinner cap. In some cases, the sugar has caused the cap and band to stick together. Applying gentle pressure with the heel of the hand should free the parts for removal.
3. Remove the element lead wire retaining screws with a ¼" (9.5mm) nut driver and remove the element lead wires from the terminals in the floss head. This will allow the band and ribbons to be removed.
4. Remove the band and ribbons. If there is excessive sugar buildup, soak the band and ribbons in hot water until the sugar dissolves. When the sugar has been removed, tap the band in the palm of your hand to loosen the ribbons for removal.
5. Inspect, then clean or replace band and ribbons. The primary reason for ribbon replacement is carbon build up inside the ribbon wire from which the heating element is manufactured. If the ribbon is being cleaned only, an additional hot water soak may help remove some of the carbon buildup.

TROUBLESHOOTING

LOW PRODUCTION

1. Check for excessive carbon on the ribbons. Follow the instructions for removing and cleaning band and ribbon if needed.
2. Check heat control for correct setting.
3. Check the line voltage. A primary reason for low production and poor equipment performance is low line voltage. Have an electrician check the line voltage and add new lines for all of the various equipment you have plugged into the electric circuit if there is not enough current for the requirement listed on the equipment nameplate.
4. Check the ribbons. For machines with two ribbons, one burned out or shorted ribbon will cut production in half.
5. Foreign objects in the head assembly may short out a ribbon or cause an out-of-balance condition.

EXCESSIVE SMOKE

1. Check heat control setting. After warm up, equipment should make good floss at a reduced setting. Never let the machine operate with the heat so high it produces smoke or if you can smell burned sugar. This condition quickly fills the ribbon with carbonized sugar.
2. Check the product mixture being used. For best results, use nothing with a cornstarch base.
3. Check the band and ribbon for excessive sugar build up and remove if needed as described on page 9 of this manual.

EXCESSIVE VIBRATION

If the equipment is new, verify that shipping bolts have been loosened and packing materials were removed from the machine.

When adding sugar to the floss head, always fill it 90% full to obtain a balanced condition in the head and eliminate vibration. DO NOT add sugar with motor running!

Check for stretched or uneven suspension springs.

Run the sugar completely out, then check for foreign objects or sugar lumps in the head assembly.

ORDERING SPARE PARTS

1. Identify the needed part by checking it against the photos, illustrations, and/or the parts list.
2. When ordering, please include part number, part name, and quantity needed.
3. Please include your model name and machine serial number (located on the machine nameplate) with your order.
4. Address all parts orders to:

Parts Department
Gold Medal Products Co.
10700 Medallion Drive
Cincinnati, Ohio 45241-4807

or, place orders at:

(513) 769-7676
Fax: (513) 769-8500
E-mail: goldme19@eos.net
Web Page: www.gmpopcorn.com

FLOSS MACHINE ASSEMBLY

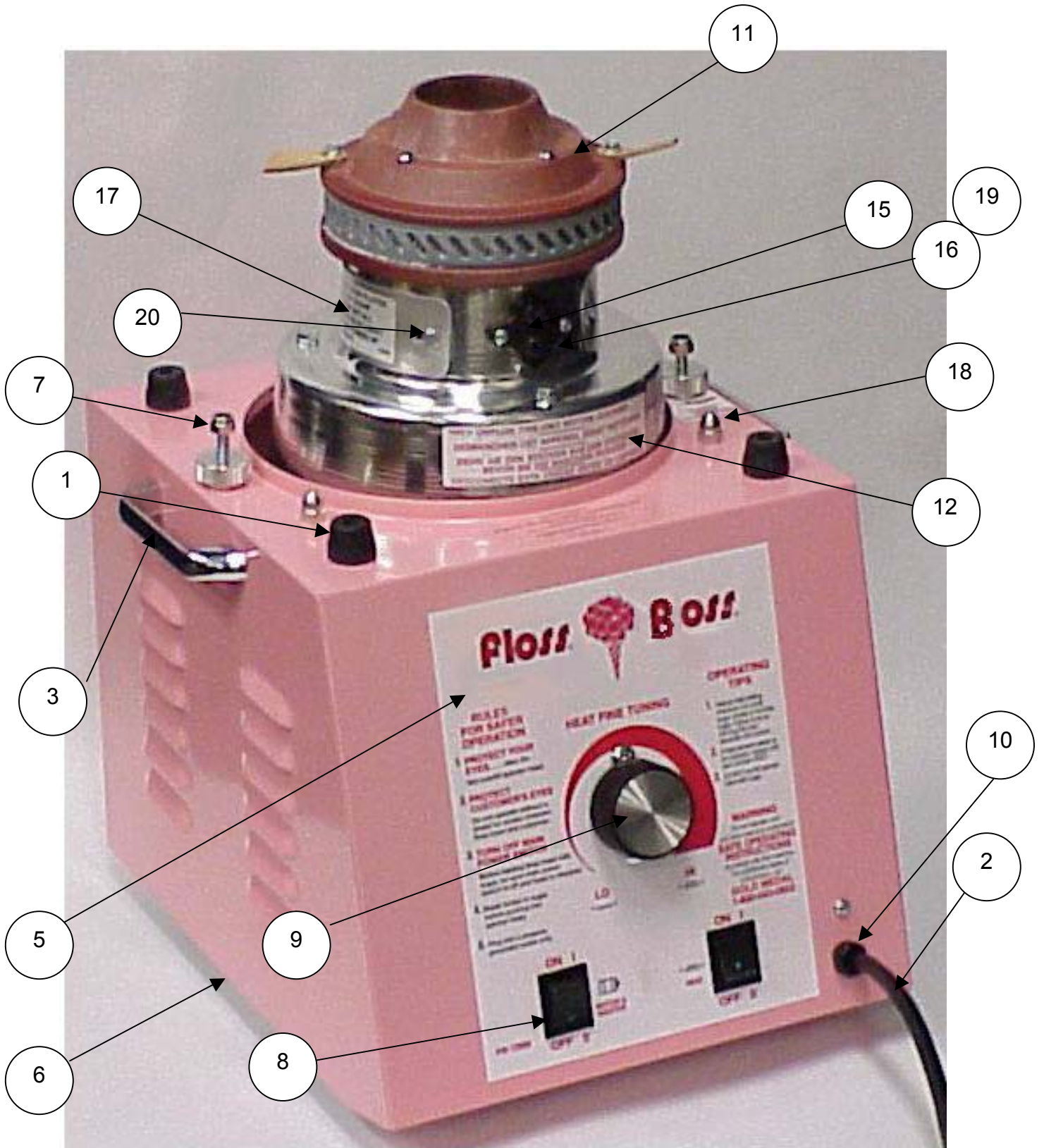

PARTS LIST CABINET ASSEMBLY

| Item No. | Part No. | Description |
|----------|----------|--|
| 1 | 47155 | Molded Recedded Bumper (8) |
| 2 | 22038 | Power Supply Cord |
| 3 | 41098 | Handle (2) |
| 4 | 42120 | Suspension Spring (3) |
| 5 | 12603 | Nameplate |
| 6 | 42448 | Bottom Plate |
| 7 | 42150 | Knob, Shipping Saddle (2) |
| | 42567 | Shipping Bracket (2) |
| 8 | 42798 | Switch, On/Off (2) |
| 9 | 42555 | Electronic Heat Control |
| | 42556 | Knob, Electronic Heat Control |
| 10 | 76026 | Strain Relief |
| 11 | 42883EX | Spinner Head Complete |
| 12 | 42190 | Bell Housing |
| 13 | 42119 | Motor Mounting Plate |
| | 42125 | Tinnerman Nut 1/4-20 (3) |
| | 75328 | Plastic Bushing, 5/16" (7.9mm) I.D. (2) |
| 14 | 42287EX | Motor 120 Volt |
| 15 | 42384 | Brush Holder Assembly (2) |
| 16 | 42138 | Brush Holder Cap (4) |
| 17 | 42381 | Inspection Cover (Screws Part No. 74148) |
| 18 | 49068 | Acorn Nut 1/4-20 |
| 19 | 42140 | Carbon Brush (4) |
| 20 | 47229 | Tinnerman Nut 8-32 (4) |
| 21 | 42297 | Motor Spacer (4) * |
| 22 | 48714 | Surge Protector * |

***Not Shown**

ELECTRICAL SCHEMATIC A.O. SMITH EXPORT

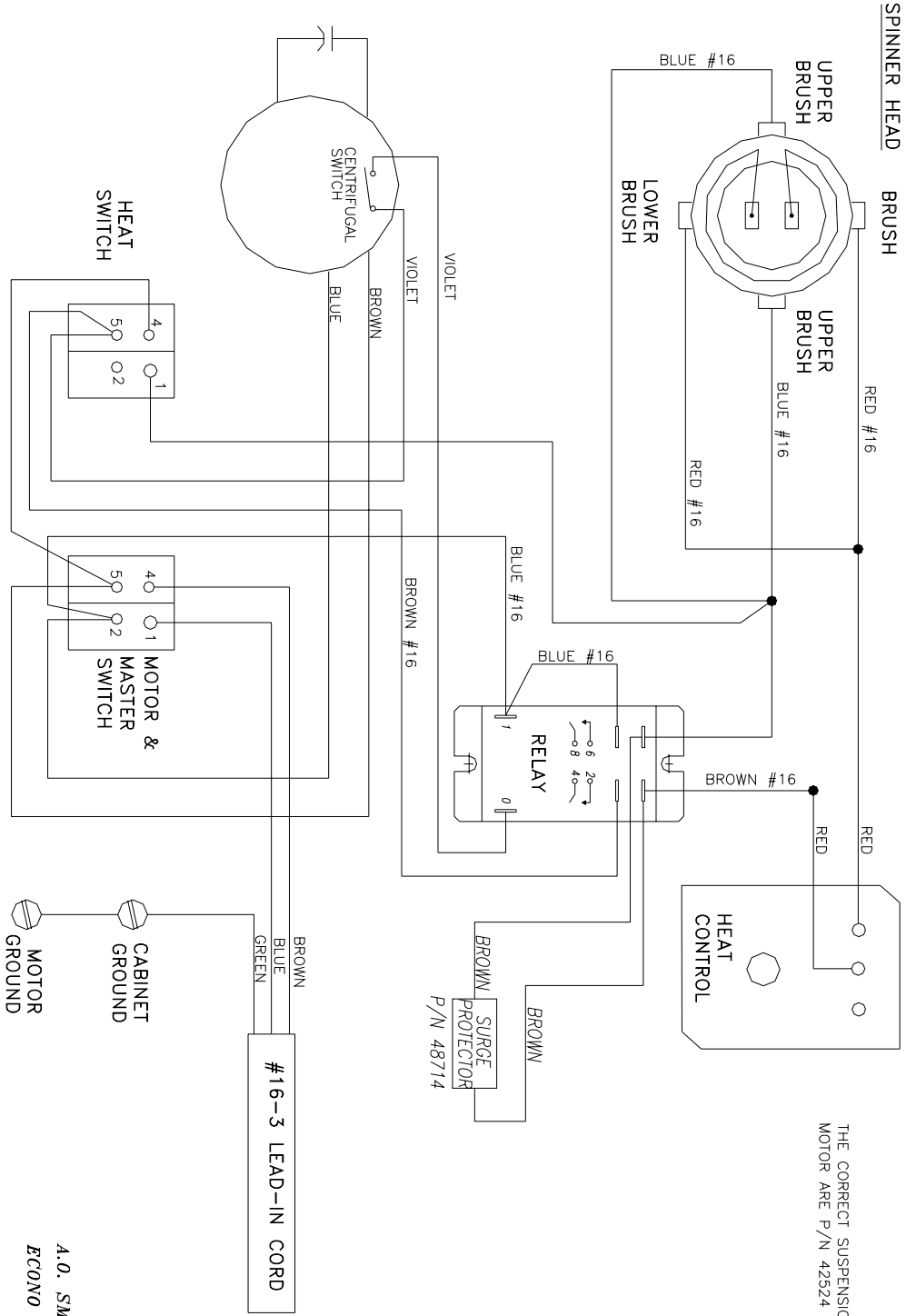

THE CORRECT SUSPENSION SPRINGS FOR THIS MOTOR ARE P/N 42524 (RED)

A.O. SMITH WIRING DIAGRAM
ECONO FLOSS - 12/02

ELECTRICAL SCHEMATIC FASCO MOTOR EXPORT

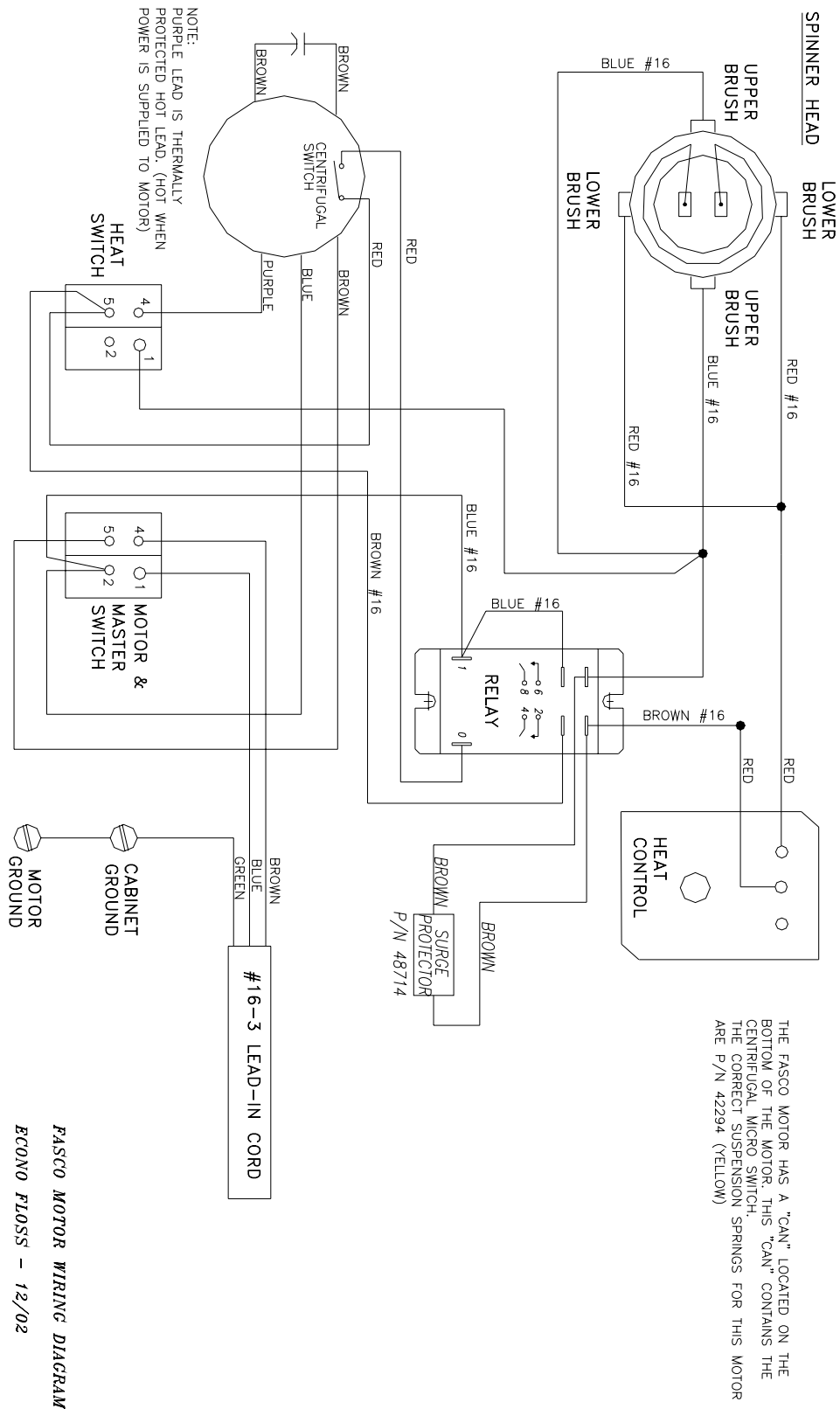

ELECTRICAL SCHEMATIC MARATHON MOTOR EXPORT

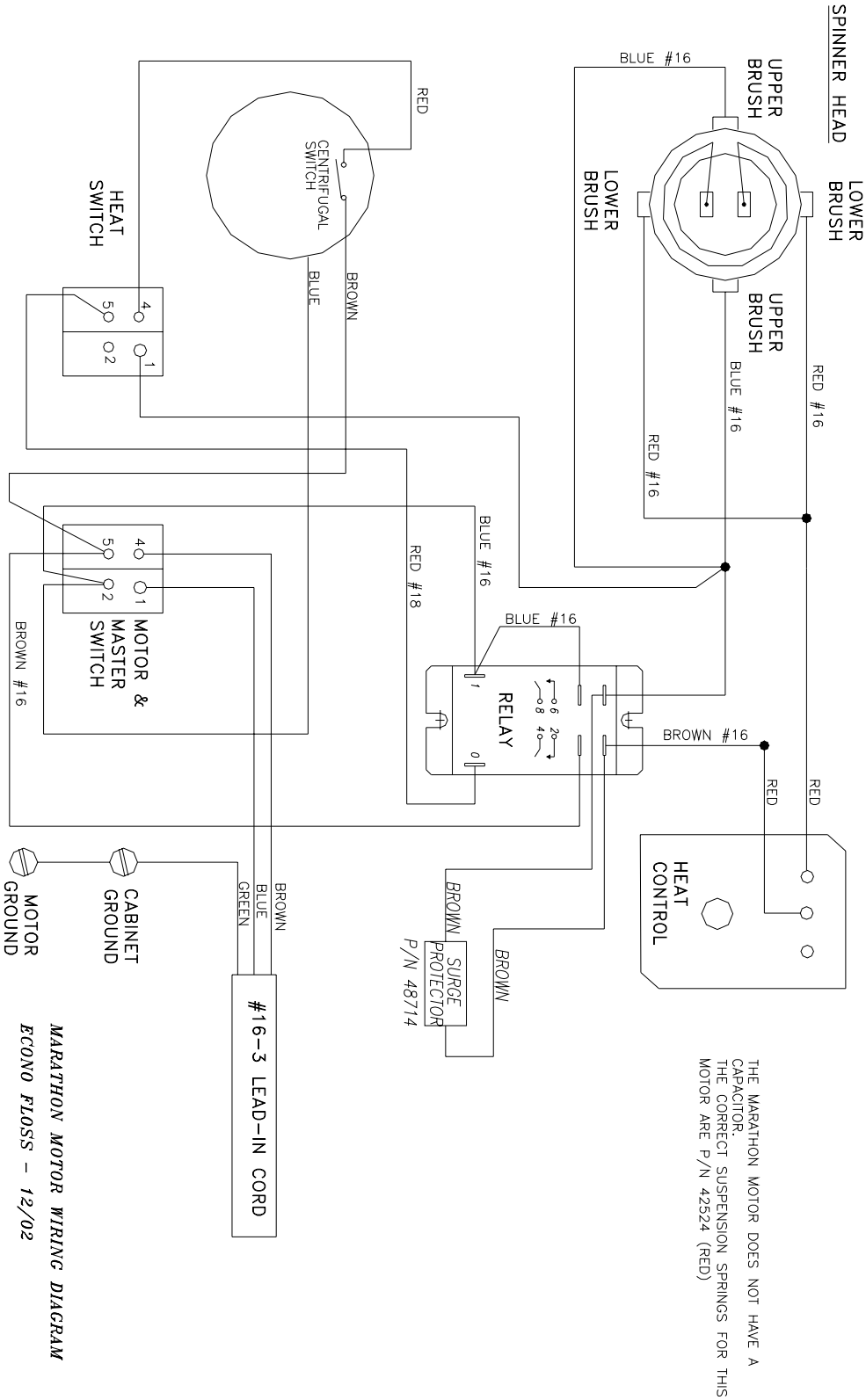

WARRANTY

WE WARRANT to the original purchaser the Gold Medal equipment sold by us to be free from defects in material or workmanship under normal use and service. Our obligation under this warranty shall be limited to the repair or replacement of any defective part for a period of six (6) months from the date of sale to the Original Purchaser with regard to labor and two (2) years with regard to parts and does not cover damage to the equipment caused by accident, alteration, improper use, voltage, abuse, or failure to follow instructions.

THIS WARRANTY IS IN LIEU OF ALL OTHER WARRANTIES EXPRESSED OR IMPLIED, AND OF ALL OTHER OBLIGATIONS OR LIABILITIES ON OUR PART, INCLUDING THE IMPLIED WARRANTY OF MERCHANTABILITY. THERE ARE NO WARRANTIES WHICH EXTEND BEYOND THE DESCRIPTION ON THE FACE HEREOF. We neither assume, nor authorize any other person to assume for us, any other obligation or liability in connection with the sale of said GOLD MEDAL equipment or any part thereof.

The term "Original Purchaser" as used in this warranty shall be deemed to mean that person, firm, association, or corporation who was billed by the GOLD MEDAL PRODUCTS COMPANY, or their authorized distributor for the equipment.

THIS WARRANTY HAS NO EFFECT AND IS VOID UNLESS THE ORIGINAL PURCHASER FIRST CALLS GOLD MEDAL PRODUCTS COMPANY AT 1-800-543-0862 TO DISCUSS WITH OUR SERVICE REPRESENTATIVE THE EQUIPMENT PROBLEM, AND, IF NECESSARY, FOR INSTRUCTIONS CONCERNING THE REPAIR OR REPLACEMENT OF PARTS.

NOTE: This equipment is manufactured and sold for commercial use only.



GOLD MEDAL PRODUCTS COMPANY
10700 Medallion Drive
Cincinnati, Ohio 45241-4807 USA