

Gas Popper

Part No. 74823EX
Revised June 1996

Instruction Manual Model #2240EX





 **GOLD MEDAL**®

FUNFOOD EQUIPMENT & SUPPLIES

Cincinnati, OH 45241-4807 USA

SAFETY PRECAUTIONS

| | |
|---|---|
|  | ⚠ CAUTION |
| | This equipment is designed and sold for commercial use only. This equipment is not to be used by the consumer in home use. Do not allow direct contact of this equipment by the public when used in food service locations. Only personnel trained and experienced in the equipment operation may operate this equipment. Carefully read all installation instructions before operating the equipment. |

| | |
|---|---|
|  | ⚠ WARNING |
| | Always wear safety glasses when servicing this equipment. |

| | |
|--|--|
|  | ⚠ WARNING |
| | To avoid serious burns, do NOT touch the kettle while it is hot. |

| | |
|---|---|
|  | ⚠ WARNING |
| | Any alterations to this equipment will void the warranty and may cause a dangerous situation. NEVER make alterations to the equipment. Make sure all machine switches are in the OFF position before plugging the equipment into a receptacle. |

| | |
|---|--|
|  | ⚠ DANGER |
| | Machine must be properly grounded to prevent electrical shock to personnel. Do NOT immerse the kettle, warmer, or any other part of this equipment in water. Always unplug the equipment before cleaning or servicing. |

NOTE

The information, specifications and illustrations contained in this manual represent the latest data available at time of publication. Right is reserved to make changes as required at the discretion of Gold Medal Products Company without notice.

INSTALLATION

MODELS

2240EX 230 Volt Motor, 50 Hz, Propane Gas

This instruction booklet is very thorough and complete. Please take the time to read this entire booklet before attempting to operate the appliance.

Your 709,7ml (24 Oz. by volume) commercial Popper is the finest 709,7ml (24 Oz. by volume) Gas Popper ever built. No expense has been spared to give you a long lasting unit to withstand the heavy loads of commercial popping. The special alloy steel kettle is extra-heavy to prevent burnouts or warping and is made from excellent heat conducting steel.

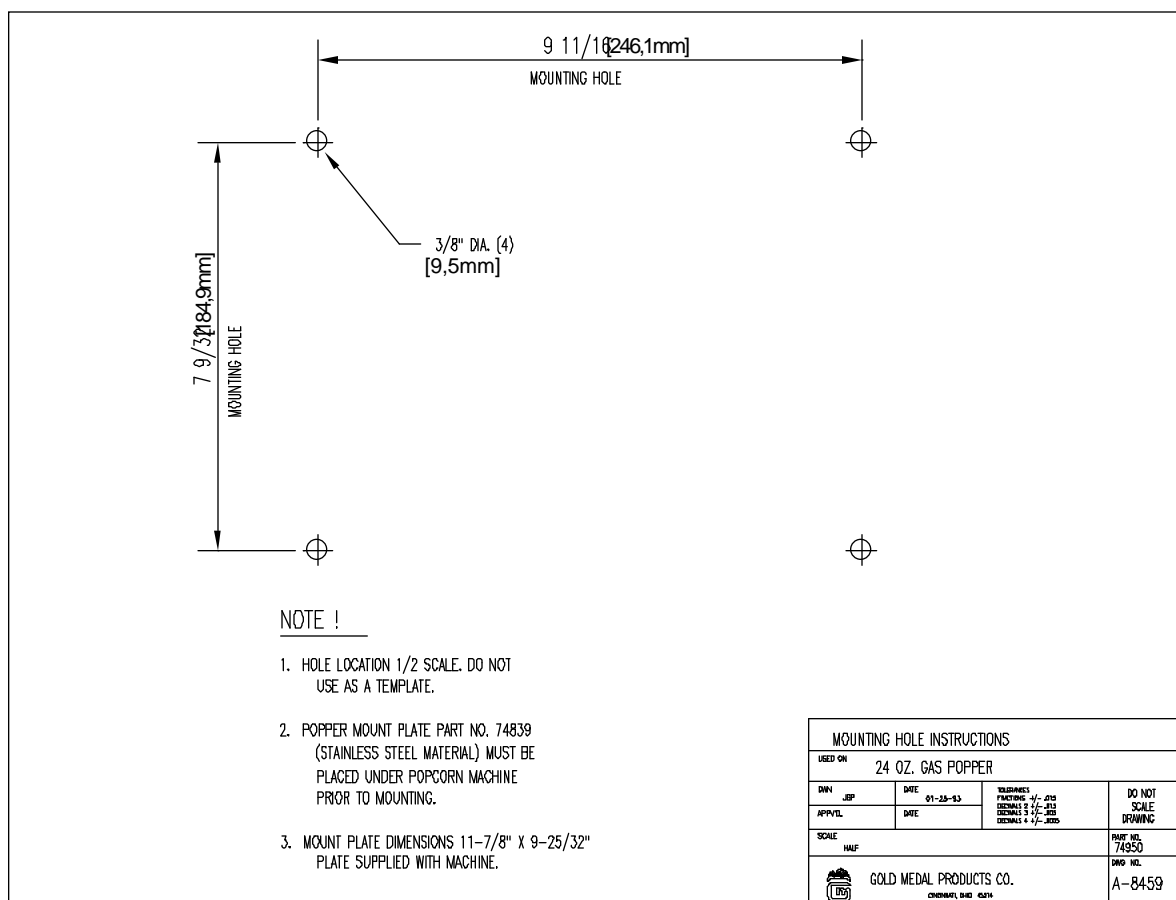

UNPACKING AND ASSEMBLY

After unpacking your 709,7ml (24 Oz. by volume) Gas Popper, set it on a counter where you intend to use it and remove all tape. Make sure clearances around the appliance comply with the marking on the data plate for the location you have selected. Bolt the Popper to the counter to secure it from tipping. Use the drilling template below for proper hole alignment.



GAS INSTALLATION

When installing your new 709,7ml (24 Oz. by volume) commercial Gas Popper, you must conform with local codes or in the absence of local codes, with the national fuel gas code, ANSI Z223.1-1992 or latest edition.

| | |
|---|---|
|  |  DANGER |
| | <p>Gas is safe when used properly, but can be very dangerous when used improperly. We suggest that installation be carefully made by qualified personnel only. Gas companies have competent service personnel to provide safe installation.</p> |



When selecting a combustible and noncombustible location for your new 709,7ml (24 Oz. by volume) Gas Popper, pay close attention to the installation clearances. The minimum clearance for the sides opposite the dump handle is 254mm (10 inches). The minimum side clearance is 762mm (30 inches). **NOTE:** Be sure to provide adequate air supply and adequate clearance for air openings into the combustion chamber. Be sure to provide adequate clearances for servicing and proper installation.

The appliance and its individual shutoff valve must be disconnected from the gas supply piping during pressure testing of the system in excess of 3.45 kpa (1/2 psig). During any pressure testing of the gas supply piping system at pressures equal to or less than 3.45 kpa (1/2 psig), the appliance must be isolated from the gas supply piping system by closing its individual manual shutoff valve.

This unit must be grounded in accordance with local codes or in the absence of local codes, with the National Electrical Code (NEC) - ANSI/NFPA 70-1992. The power supply cord on your Popper includes a grounding pin. Do not alter or remove this pin! Also, make sure you plug your unit into a grounding receptacle only.

When wiring your new 709,7ml (24 Oz. by volume) Gas Popper, refer to the wiring diagram located inside the cabinet of the appliance and in this instruction booklet (Drawing a-8149).

After installation, all gas connections must be checked for leaks with a soap solution.

| | |
|---|---|
|  |  DANGER |
| | <p>Do not use a match or flame to check for leaks - you may cause a fire or explosion! When gas connections are complete, wire the unit to a power source which will carry the current specified on the units data plate.</p> |

TYPES OF GAS

The manneplate is marked at the factory to indicate the type of gas your appliance uses, either propane or natural. If necessary the appliance can be altered to switch fuels, but we suggest only qualified personnel do the work. Please have your qualified personnel refer to the maintenance and repair section of this instruction booklet.

ALTITUDE RANGE

The factory has sized the burner orifices for an elevation up to 609,8m (2000 feet) above sea level. For high altitude operation contact Gold Medal customer service department.

GAS PRESSURE

We have determined that optimum popping occurs when the gas pressure is adequate. For propane gas we recommend a manifold pressure setting of 254mm (10 inches) of water column [177,4ml/sq. mm] (6 oz/sq in) and for natural gas 101,6mm (4 inches) of water column [59,1ml/sq. mm] (2 oz/sq in). The pressure is measured at the appliance while the main burner is ignited. A pressure regulator is supplied to deliver the optimum pressure for both types of gas when the unit is changed from the original factory specification. Follow instructions in the maintenance and repair section of this instruction manual. Adequate gas requirements are maintained by proper pipe sizing. Be sure to use properly sized pipe to supply the needed pressure.

LIGHTING AND SHUT-DOWN INSTRUCTIONS



Another fine feature of your 709,7ml (24 Oz. by volume) Gas Popper is the “manual spark igniter”. You can throw your matches away. Simply depress the red button on the unit, and it internally releases a spark at the pilot. If gas is present, a flame will result. On a new installation (or if you run out of propane), it is possible to have air in the line. Lines may be purged by loosening a connection at some point. This must be done very carefully by qualified personnel, and time must be allowed for gas to dissipate before attempting to re-light (usually five minutes).

1. Turn the gas safety valve handle to the “PILOT” position.
2. Push down safety valve reset button and depress the spark igniter. Repeat until pilot lights. Continue holding the reset button for 30-45 seconds, until the pilot remains burning when the button is released.
3. Turn the gas safety valve handle to the “ON” position. The main burner should now ignite from the pilot burner.
4. Should you want to turn both the pilot and main burner off, pull the gas safety valve and turn the handle to the “OFF” position.

TO MAKE POPCORN



Turn the main burner on. Put oil in the kettle. You may let oil heat in kettle before adding popcorn and salt. We recommend 709,7ml (24 Oz. by volume) of corn, 236,6ml (8 Oz. by volume) of high quality coconut oil and Flavacol salt to get the best results. An accurate measure of oil and Flavacol is the secret to great tasting popcorn, popcorn that brings back repeat customers. If you are in a commercial pre-pop operation, this is even more important. Good quality popcorn commands a high price, and to your customer it is well worth the slightly higher price.

You may put more popcorn into the kettle, but this will lengthen the popping cycle and your overall production will decrease. You can make smaller batches if necessary, but always use a corn to oil ratio of 3:1. Also, when making small batches, you may want to turn the main burner flame down to prevent it from getting too hot.

IF THE FLAME GOES OUT

A five minute shut down period is required before attempting to re-light.

1. Check to see if you are out of gas.
2. Check to see if the thermocouple is in proper position.

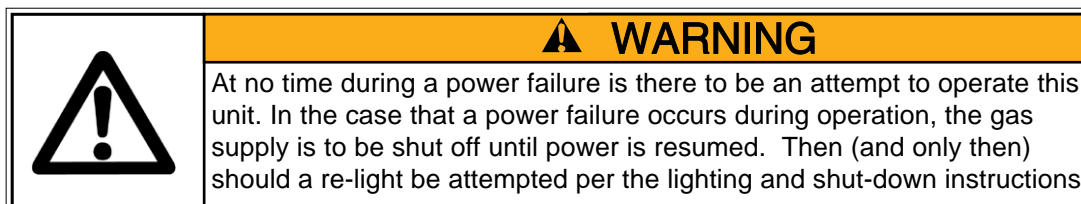



TO CLEAN KETLE

Unplug machine before cleaning. In order to keep your popper working efficiently, wipe the inside of the kettle with a damp cloth. There is no need to clean using a detergent, since this will only remove the oil.

MAINTENANCE INSTRUCTIONS

| | |
|---|--|
|  | ⚠ CAUTION |
| | THE FOLLOWING SECTIONS OF THIS MANUAL ARE INTENDED ONLY FOR QUALIFIED SERVICE PERSONNEL WHO ARE FAMILIAR WITH ELECTRICAL EQUIPMENT. THESE ARE NOT INTENDED FOR THE OPERATOR. |

| | |
|---|--|
|  | ⚠ WARNING |
| | Adequate eye protection must be used when servicing this equipment to prevent the possibility of injury. |

| | |
|---|---|
|  | ⚠ DANGER |
| | Do NOT immerse the equipment in water. Unplug your machine before servicing. |

LUBRICATION REQUIREMENTS

DRIVE MOTOR

This is a sealed-bearing type motor and requires no lubrication.

GAS CONVERSION

1. Disconnect the power supply at the fuse box or breaker.
2. Turn the gas supply line off.
3. Refer to wire diagram drawings.
4. Conversion orifices are located in motor compartment of appliance, behind access panel.
5. Place the kettle in dump position. Replace the main burner hood with appropriate part number for the intended type of gas.
 - A. Part no. 74817 (#55) for Propane Gas.
 - B. Part no. 74836 (#46) for Natural Gas ("NAT").
6. Replace the pilot burner orifice with appropriate part number for the intended type of gas.
 - A. Part no. 74029 (.28mm [.011"] Dia. holes) for Propane Gas.
 - B. Part no. 74531 (.46 [.018"] Dia. holes) for "NAT" Gas.
7. Remove the hex cap on the pressure regulator and position the appropriate end of the red plug down. "LP" means Propane Gas; "NAT" means Natural Gas.
8. Replace the hex cap. **NOTE:** Orifice spuds must be screwed tight when propane gas is used.
9. Turn gas supply on and leak-test all connections with a soap solution.
10. Turn main power on.

ORDERING SPARE PARTS

1. Identify the desired part by checking it against the photos, illustrations, and/or the parts list.
2. When ordering, please include part number, part name, and quantity desired.
3. Please include your model name and machine serial number (located on the machine nameplate) with your order.
4. Address all parts orders to:

Parts Department
Gold Medal Products Co.
10700 Medallion Drive
Cincinnati, Ohio 45241-4807

or, place orders at:

(513) 381-1313
Fax: (513) 381-1570
E-mail: goldme19@eos.net

GAS POPPER ASSEMBLY – SIDE VIEW

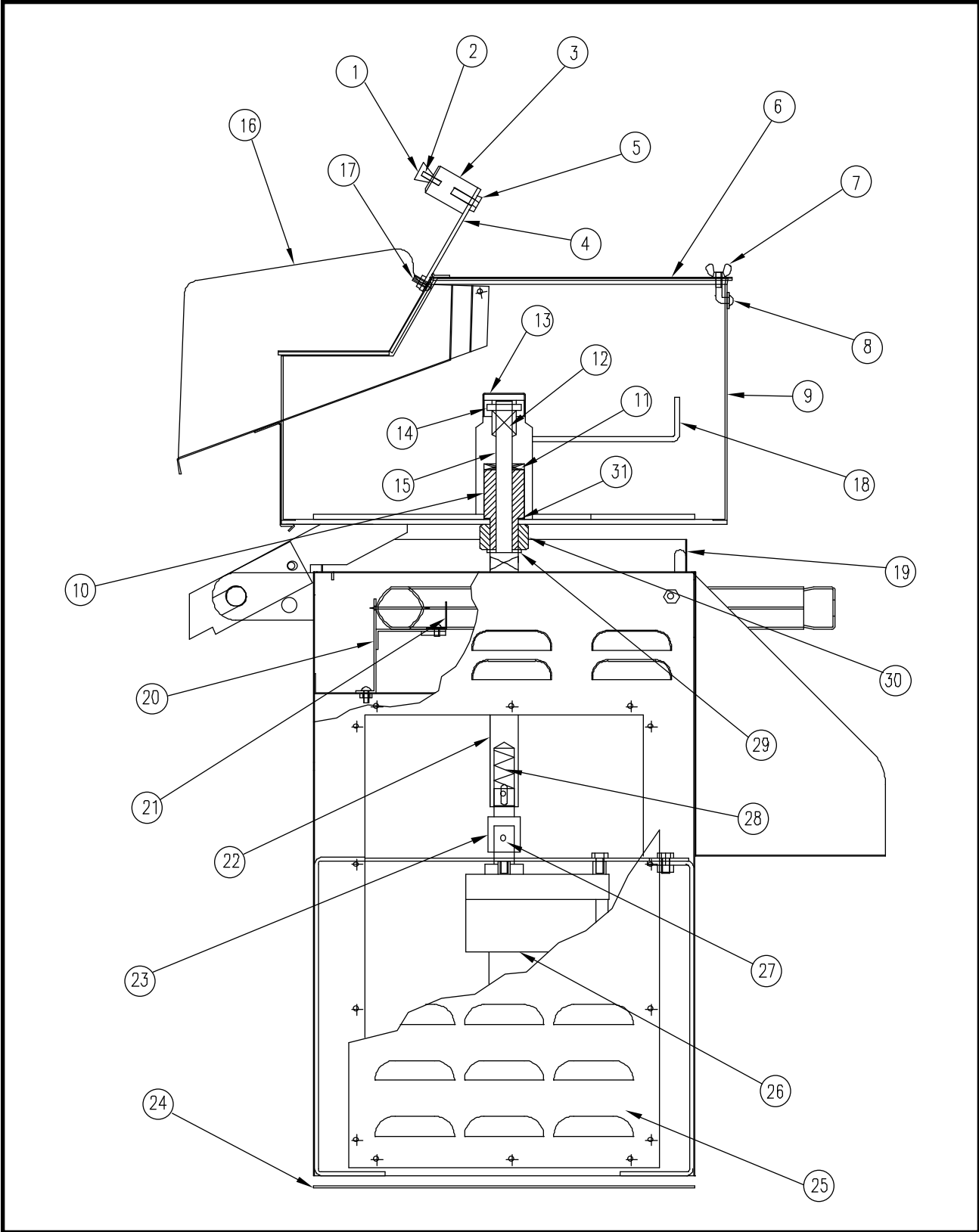

PARTS LIST – POPPER SIDE VIEW

| Item No. | Part No. | Description |
|----------|----------|--------------------------------|
| 1 | 47120 | Knob, Lid Lift |
| 2 | 74571 | Set Screw, #8-32 x 15,9mm |
| 3 | 82108 | Counter Weight |
| 4 | 82105 | Counter Weight Bar |
| 5 | 74520 | Bolt, 1/4-20 |
| 6 | 82125 | Kettle Lid Assembly w/o Oil |
| 7 | 74118 | Wing Nut, #10-24 (4) |
| 8 | 74001 | Screw, Lid Hold Down (4) |
| | 74088 | Rubber Seal, Lid Hold Down (4) |
| | 74117 | Flat Washer (4) |
| 9 | 74816 | Kettle Only, 24 Oz. Popper |
| 10 | 74004 | Kettle Bearing Hub Assembly |
| 11 | 27039 | Bellville Washer (2) |
| 12 | 41138 | Agitator Spring |
| 13 | 27038 | Hub Cap, Agitator |
| 14 | 10072 | Dowel Pin, 3/16" x 31,8mm |
| 15 | 74003 | Upper Agitator Drive Shaft |
| 16 | 74815 | Kettle Dump Chute Assembly |
| 17 | 74146 | Hex Nut, #8-32 Eslok (2) |
| 18 | 74820 | Agitator Assembly |
| 19 | 74837 | Heat Shield Assembly |
| 20 | 74826 | Burner Support Assembly |
| 21 | 74827 | Burner Retainer Angle |
| 22 | 74822 | Lower Agitator Drive Shaft |
| 23 | 82287 | Coupling, Drive Motor |
| 24 | 74839 | Popper Mount Plate |
| 25 | 74802 | Front Cover |
| 26 | 82085 | Kettle Drive Motor, 120 Volt |
| | 82413 | Kettle Drive Motor, 230 Volt |
| | 74819 | Kettle Drive Motor, 12 Volt DC |
| 27 | 82067 | Set Screw, 1/4-28 x 6,4mm |
| 28 | 74013 | Spring, Output Coupling |
| 29 | 74006 | Washer, Bronze Thrust |
| 30 | 74106 | Nut, Hex Jam 7/8-14 |
| 31 | 74007 | Washer, Compression |

GAS POPPER ASSEMBLY – BOTTOM VIEW

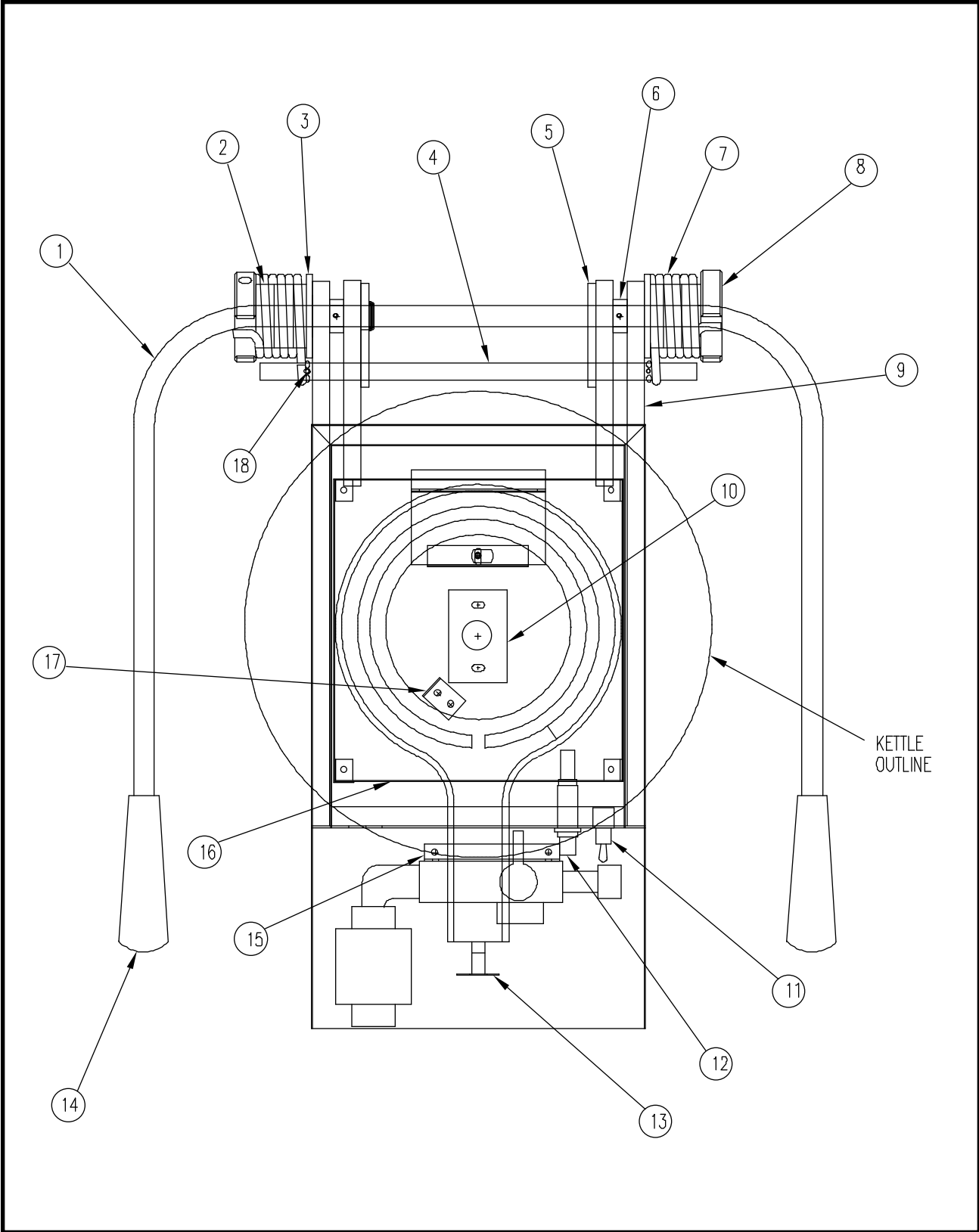

PARTS LIST – POPPER BOTTOM VIEW

| Item No. | Part No. | Description |
|-----------------|-----------------|-----------------------------|
| 1 | 74113 | Dump Bar Handle Assembly |
| 2 | 74658 | Spring Spacer (4) |
| 3 | 74690 | Large Spacer (2) |
| 4 | 74848 | Kettle Stop Rod |
| 5 | 74019 | Kettle Stop Plate |
| 6 | 74828 | Kettle Spacer (2) |
| 7 | 74660 | Torsion Spring (2) |
| 8 | 74661 | Collar (2) |
| 9 | 74803 | Kettle Mount Bar (2) |
| 10 | 74808 | Air Shield |
| 11 | 41016 | Motor Switch, 120 Volt |
| 12 | 74849 | Spark Igniter |
| 13 | 74800 | Round Sheet Metal Burner |
| 14 | 57028 | Plastic Handle (2) |
| 15 | 74846 | Mount Bracket, Safety Valve |
| 16 | 74837 | Heat Shield Assembly |
| 17 | 74833 | Mount Bracket, Pilot Burner |
| 18 | 77492 | Cotter Pin (2) |

ELECTRICAL SCHEMATIC

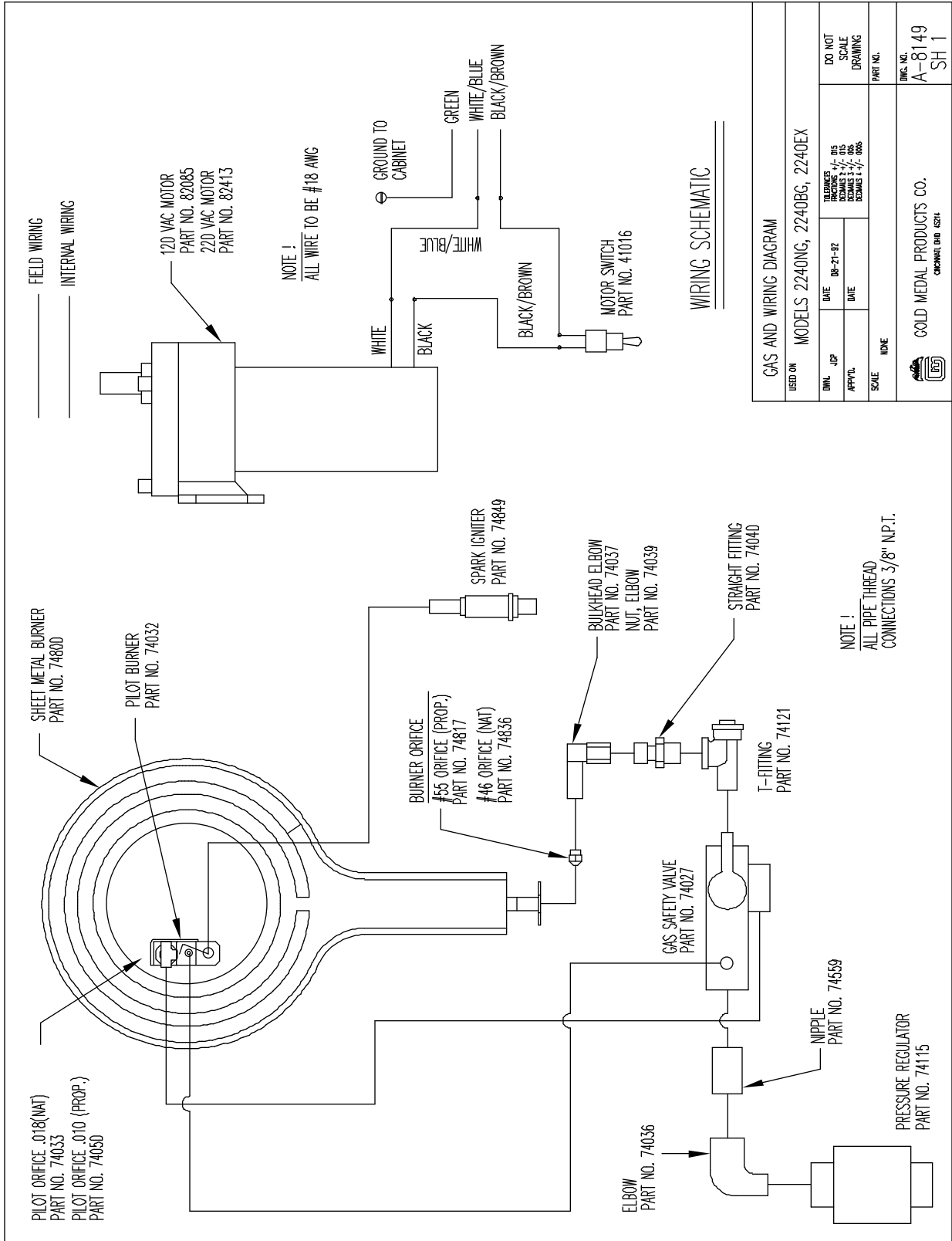

WARRANTY

WE WARRANT to the original purchaser the Gold Medal equipment sold by us to be free from defects in material or workmanship under normal use and service. Our obligation under this warranty shall be limited to the repair or replacement of any defective part for a period of six (6) months from the date of sale to the Original Purchaser with regard to labor and two (2) years with regard to parts and does not cover damage to the equipment caused by accident, alteration, improper use, voltage, abuse, or failure to follow instructions.

THIS WARRANTY IS IN LIEU OF ALL OTHER WARRANTIES EXPRESSED OR IMPLIED, AND OF ALL OTHER OBLIGATIONS OR LIABILITIES ON OUR PART, INCLUDING THE IMPLIED WARRANTY OF MERCHANTABILITY. THERE ARE NO WARRANTIES WHICH EXTEND BEYOND THE DESCRIPTION ON THE FACE HEREOF. We neither assume, nor authorize any other person to assume for us, any other obligation or liability in connection with the sale of said GOLD MEDAL equipment or any part thereof.

The term "Original Purchaser" as used in this warranty shall be deemed to mean that person, firm, association, or corporation who was billed by the GOLD MEDAL PRODUCTS COMPANY, or their authorized distributor for the equipment.

THIS WARRANTY HAS NO EFFECT AND IS VOID UNLESS THE ORIGINAL PURCHASER FIRST CALLS GOLD MEDAL PRODUCTS COMPANY AT 1-800-428-2676 TO DISCUSS WITH OUR SERVICE REPRESENTATIVE THE EQUIPMENT PROBLEM, AND, IF NECESSARY, FOR INSTRUCTIONS CONCERNING THE REPAIR OR REPLACEMENT OF PARTS.

NOTE: This equipment is manufactured and sold for commercial use only.



GOLD MEDAL PRODUCTS COMPANY
10700 Medallion Drive
Cincinnati, Ohio 45241-4807 USA